

NOTE:

Substrate to comply with current Viking Roofspec Masterspec specification
Substrate Checksheet available from www.vikingroofspec.co.nz

NOTE:

Consider Viking Detail TOR_011 as a better option for supporting Mechanical Plant on membrane roofs.

Although Viking Roofspec do not recommend fixing posts or plant through the top of Membrane roofs or decks if this is required then use a plinth detail provides the fixing by other trades are kept off the main deck flood area.

Viking Roofspec recommend that any fixing of plant is kept independent of the membrane roof ideally through vertical surfaces such as parapets.

All Fixings must be sealed

NOTE:

Viking Roofspec or our Approved Applicators do not warranty fixings installed by other trades.

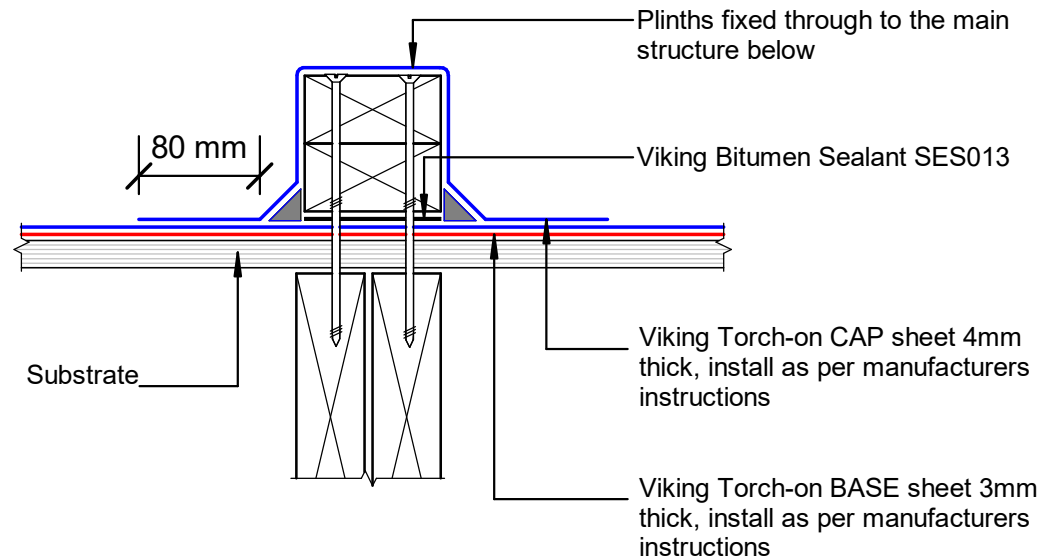
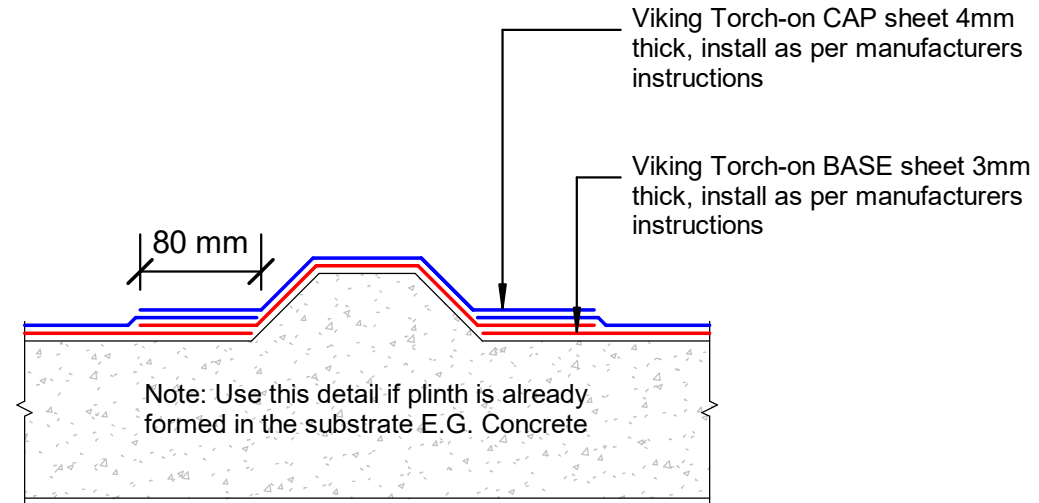

DRAWING TITLE

Viking Torch-On
Penetration_Plinth for concrete or timber

NOTES:

- Viking Waterproof Membrane as notated can be Viking Gemini, Lybra or Phoenix Super.
- All fixings, cladding and structure are indicative only unless notated.



Viking Torch-On systems are CodeMarked

DRAWING

INFORMATION ONLY

Scale:	Date:	Drawn:	Viking
Not to Scale	23/11/2020		
Detail Ref: VIK_TOR_013_PENEPLIN			

